

DATA SHEET

FQ1216AME MK4 Multi-Standard Miniature Video Module

Product specification

Approval by :

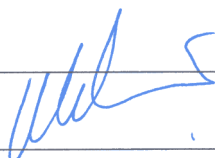

Name / Date : Toh Kong Lim/ 01.06.2005

PHILIPS

Multi-Standard Miniature Video Module**FQ1216AME MK4****FEATURES**

- Miniaturized frontend module suitable for Notebook applications
- Multi-Standard TV Systems Broadcast reception
- True 5 V device (low power dissipation)
- Full frequency range from channel E2 (48.25 MHz) to channel E69 (855.25 MHz)
- Integrated LNA for good sensitivity
- PLL controlled tuning
- Programmable PLL step size (31.25 / 50 kHz or 62.5 kHz)
- True-synchronous vision IF demodulator (PLL)
- Ultra linear FM PLL demodulator
- Demodulated video output, AF sound output, second IF sound output.
- I²C-bus control of tuning, address selection, AFC status information
- Complies with European regulations on radiation, signal handling and immunity ("CENELEC 55020, 55013")
- Low profile horizontally mounted metal 58 x 36 x 6.8 mm³ housing

**ORDERING INFORMATION**

TYPE	DESCRIPTION	ORDER NUMBERS
FQ1216AME/R H-4	RF Pin Input / Horizontal Mounting	3139 147 21611

MARKING

The following items of information are printed on a sticker that is on the top cover of the tuner:

- Type number
- Code number
- Origin letter of factory
- Change code
- Year and week code

Multi-Standard Miniature Video Module**FQ1216AME MK4****DESCRIPTION**

The FQ1216AME family belongs to the new FM1200 MK 4 family of low profile frontends, which are designed for Notebook TV and portable TV applications. The FQ1216AME combines the functions of Low Noise Amplifier module, an all-band TV tuner, and a multi-standard TV IF demodulation unit for both positive and negative modulated TV systems. The FQ1216ME is intended for CCIR L/L' (France), B/G, I and D/K systems.

The frontends have a built-in digital (I²C) PLL tuning system. A DC-DC converter circuit is built-in in the FQ1216AME to synthesize the tuning voltage required, thus making the frontend a true 5V device.

The FQ1216AME/H-4 is biased for extreme sensitivity, so care has to be taken in large signal application.

INTERMEDIATE FREQUENCIES

SYSTEM	L	L'	B/G	D/K	I
Picture carrier	38.90	33.95	38.90	38.90	38.90
Colour	34.47	38.38	34.47	34.47	34.47
Sound 1	32.40	40.40	33.40	32.40	32.90
Sound 2	-	-	33.16	-	-
NICAM	33.05	39.80	33.05	33.05	32.348

CHANNEL COVERAGE

BAND	FREQUENCY (MHz)
Low band	48.25 to 158.00 MHz ⁺
Mid band	160.00 to 442.00 MHz
High band	442.00 to 863.25 MHz

+ Can cover down to 45.75 MHz (Ch A for Ireland)

Multi-Standard Miniature Video Module**FQ1216AME MK4****PINNING**

SYMBOL	PIN	DESCRIPTION
N.C.	1	(AGC Monitor) Do Not Connect *
N.C.	2	(Tuning Voltage Monitor) Do Not Connect *
+5V	3	Supply Voltage Vb, Tuner section
SCL	4	I ² C-Serial Clock
SDA	5	I ² C-Serial Data
AS_Tuner	6	I²C-Address Select- Tuner part. See Pg 10. See also pg 20
NC	7	Do Not Connect (IF) *
NC	8	Do Not Connect (IF) *
2 nd IF sound	9	Second IF sound output
CVBS	10	Composite Video Baseband Signal
AS_IF	11	I²C-Address Select- IF part See also Pg 20
AF O/P	12	AF sound output
GROUND		Mounting Tags (TH1,TH2,TH3,TH4,TH5)

* For process use only

Multi-Standard Miniature Video Module**FQ1216AME MK4****LIMITING VALUES****Limiting values under operational conditions**

The tuners are guaranteed to function properly under the following conditions.

SYMBOL	PARAMETER	PIN	MIN.	TYP.	MAX.	UNIT
V _{AGC}	AGC Voltage Monitor (not to be connected) (See Note 1)	1	10 M			Ω
V _T	Tuning Voltage Monitor (not to be connected)	2	-	-	-	-
V _S	Supply Voltage V _b Ripple susceptibility (see Note 2) 20Hz - 1kHz 1kHz - 200kHz Supply current	3	4.75	5 240	5.25 2 10 280	V mVpp mVpp mA
V _{SCL}	SCL bus input voltage	4	-0.3		5.25	V
V _{SDA}	SDA Bus input voltage SDA Bus current (open collector)	5	-0.3 -1.0		5.25 5	V mA
	AS_Tuner voltage (see Note 3)	6			5.25	V
	2 nd IF sound output - Load impedance D.C. A.C.	9	1.0 1.0			kΩ kΩ
	Composite Video Baseband Signal - Load impedance D.C. (see 10.3) (modulus) A.C. - Load time constant	10	75 75		100	Ω Ω ns
	AS_IF voltage (see Note 3)	11			5.25	V
	AF output - Load impedance D.C. A.C.	12	100.0 10.0			kΩ kΩ

Note 1 : Minimum impedance required is 10MΩ, otherwise AGC voltage is loaded down. For process only.

Note 2 : Maximum allowable Ripple voltage superimposed on the +5V supply in the frequency range from 20 Hz to 500 kHz. Criteria : for TV : $\Delta f < 2.12$ kHz or AM < 0.28%

Note 3 : For detailed information about address coding, refer to Application Information.

Multi-Standard Miniature Video Module**FQ1216AME MK4****Environmental conditions**

SYMBOL	PARAMETER	CONDITIONS	MIN.	MAX.	UNIT
Non-operational Conditions					
T _{AMB}	Ambient temperature		-25	+85	°C
RH	Relative humidity		-	100	%
g _B	Bump acceleration	25 g	-	245	m/s ²
g _S	Shock acceleration	50 g	-	490	m/s ²
	Vibration amplitude	(10-55 Hz)	-	0.35	mm
Operational conditions					
T _{AMB}	Ambient temperature		0	+70	°C
RH	Relative humidity		-	95	%

(1) The typical MTBF is about 20,000 hours at this operational ambient temperature. For every 10 °C increase, the MTBF is reduced by half.

OVERALL PERFORMANCE**Conditional data**

Unless otherwise specified, all electrical values for "Overall performance" apply at the following conditions.

SYMBOL	PARAMETER	VALUE	UNIT
T _{AMB}	ambient temperature	25 ± 5	°C
RH	relative humidity	60 ± 15	%
V _S	supply voltage (tuner and IF section)	5 ± 0.125	V
Z _{S(AE)}	aerial source impedance (unbalanced)	75	Ω
Z _{IF}	second IF sound output load	0.5	kΩ
	Video output load	75	Ω
V _{ST}	AF1 sound output load	100	kΩ

Multi-Standard Miniature Video Module**FQ1216AME MK4****TUNER CHARACTERISTICS**

EQUIPMENT	PARAMETER	VALUE	UNIT
DC Voltmeter	input impedance	10	M Ω
Oscilloscope	input impedance	1	M Ω
	resistance		pF
	capacitance	15	
Spectrum analyzer	input impedance	50	Ω
FET probe	input impedance	10	M Ω
	resistance		pF
	capacitance	3.5	

Multi-Standard Miniature Video Module

FQ1216AME MK4

TEST DIAGRAM

The frontend characteristics are measured according to the test diagram depicted below :

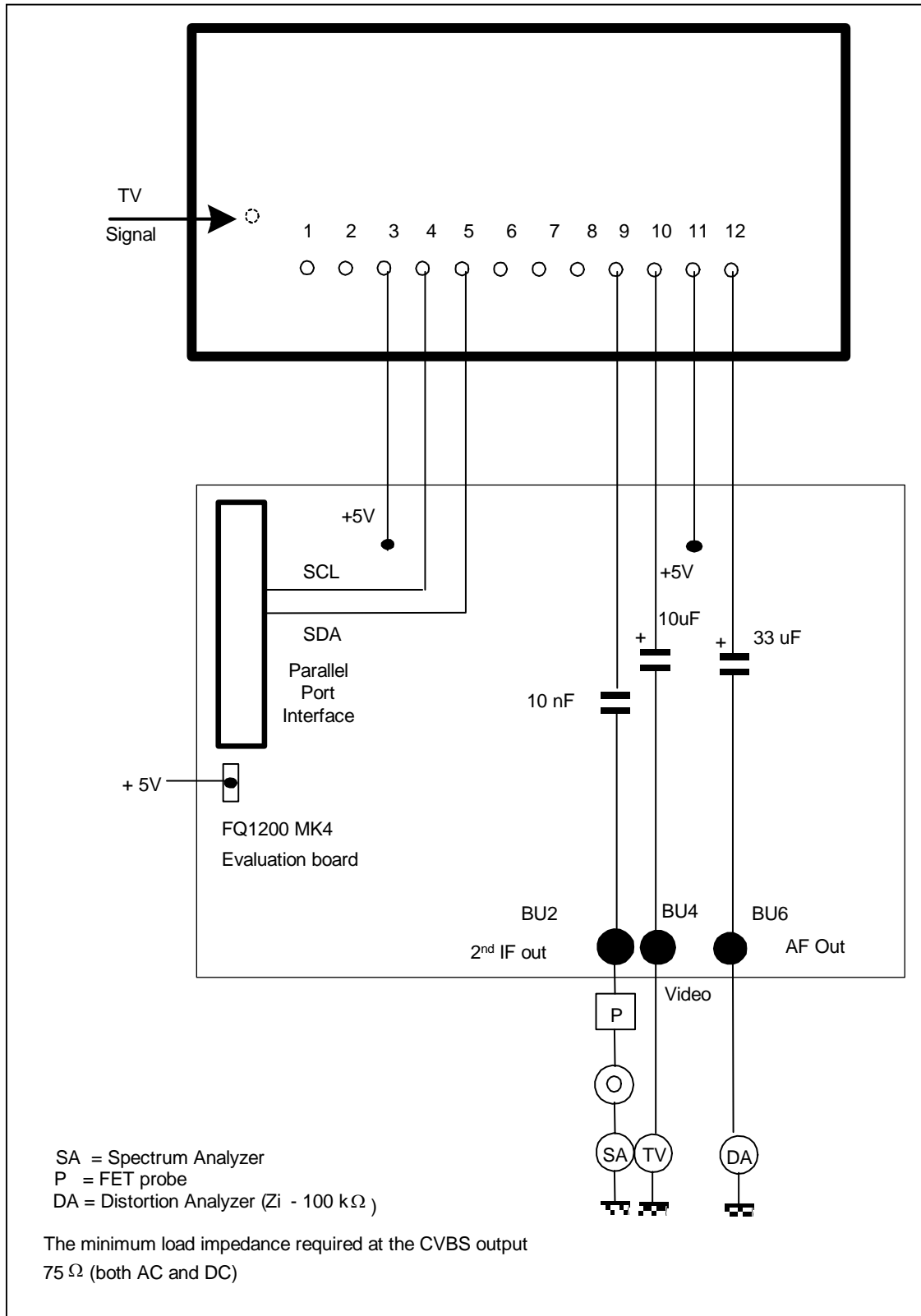

Multi-Standard Miniature Video Module**FQ1216AME MK4****Definitions of test signals**

TEST SIGNAL	FREQ. (MHz)	AMPLITUDE	MODULATION
A0: unmodulated vision carrier	480.25	60 dB(μ V)	
A1: L-system signal with video modulation	480.25	60 dB(μ V) (peak white)	100 % (sync. level at 0%), 2T-pulse and bar, unless otherwise indicated.
A2: B/G/D/K/I -system signal with video modulation	480.25	60 dB(μ V) (top sync.)	100% (rest carrier 10%), 2T-pulse and bar, unless otherwise indicated
A3: L' - system signal with video modulation.	55.75	60 dB(μ V) (peak white)	100% (sync. white < 6%), 2T pulse and bar, unless otherwise indicated
B1: unmodulated main sound carrier B/G/I/D/K system as chosen	A2 + 5.5/6.0/6.5 MHz	-13 dB respectively wrt A2	
B2: AM-modulated sound carrier L-system	486.75 MHz	-10 dB with respect to test signals A0 or A1	m=0.54, mod. freq. 1 kHz, unless otherwise indicated
B3: FM-modulated main sound carrier B/G/I/D/K system respectively	A2 + 5.5/6.0/6.5 MHz	-13 dB respectively wrt A2	freq.dev.=27 kHz, mod.freq. 1kHz, 50 μ s pre-emphasis, unless otherwise indicated
B4: unmodulated 2nd sound carrier B/G – system	A2 + 5.85 MHz	-20 dB respectively wrt A2	
B5: unmodulated main sound carrier L system	A1 + 6.5 MHz	-10 dB wrt test signal A1	
B6: AM modulated sound carrier L' system	A3 - 6.5 MHz	-10 dB wrt test signal A3	M = 0.54, mod. freq. 1 kHz, unless otherwise indicated

Multi-Standard Miniature Video Module**FQ1216AME MK4****AERIAL INPUT CHARACTERISTICS**

SYMBOL	PARAMETER	CONDITIONS	MIN.	MAX.	UNIT
VSWR		referred to 75 Ω at RF picture carrier frequency	-	5	
V _{SURGE}	surge protection		5		kV
V _{ANT}	antenna terminal disturbance voltage	up to 1.75 GHz	-	46	dB μ V

LNA CHARACTERISTICS**Gain and Noise Figure**

SYMBOL	PARAMETER	CONDITIONS	MIN.	TYP.	MAX.	UNIT
G _v	Voltage gain		8	10	12	dB
F	Noise Figure		-	3.5	6	dB

GENERAL CHARACTERISTICS

SYMBOL	PARAMETER	CONDITIONS	MIN.	TYP.	MAX.	UNIT
f _b	frequency range low band mid band high band		48.25 160.00 442.00		158.00 442.00 863.25	MHz MHz MHz
Δ f _b	margin low band mid/high band		1.5 1.5			MHz MHz
voltage gain	low band mid band high band		48 48 47	55 55 53	62 62 60	dB dB dB
α_j	Image rejection low band mid band high band (below 800MHz) high band (for 800MHz and above)	- wanted test signal F _{ant} at 60 dBuV - unwanted test signal at (F _{ant} + 77.7) MHz	65 60 50 48			dB dB dB dB
α_{IF}	IF rejection All bands	- wanted test signal F _{ant} . - unwanted test signal A0 with frequency (F _{IF,PC} - 1) MHz	60			dB
t _{ij}	Oscillators lock-in time	Tuning speed (lock bit, CP = 1)			150	ms
V _{ESD}	ESD protection at the terminals	All terminals of each frontend are protected against electrostatic discharge up to The products are classified in category B (MIL-STD-883C).	2			KV
	Maximum signal handling	F _{wanted}	90	100	-	dB μ V

Multi-Standard Miniature Video Module**FQ1216AME MK4****Video and audio characteristics**

PARAMETER	TEST SIGNAL	TEST POINT	MIN.	TYP.	MAX.	UNIT
CVBS output level Amplitude video signal	A1	BU4	0.7	1.0	1.3	Vpp
DC level of sync. Pulse	A1	BU4		0.35		V
CVBS amplitude at discrete frequencies						
2 MHz	A1	BU4		0.0	- 1.5	dB
3 MHz	A1	BU4		- 0.5	- 2.5	dB
4.43 MHz	A1	BU4		-1.0	- 4.0	dB
<u>Sound Carriers Rejection</u> Specification valid for : B/G, I and D/K mode wrt 1 MHz for :	A2 + B1 + B4	BU4				
5.5/6.0 MHz			42			dB
6.5 MHz			40			dB
<u>Unweighted CVBS Signal to Noise Ratio</u> Specification valid for : L/L', B/G, I, D/K modes	A1 or A2 or A3	BU4	40	44		dB
Unweighted SNR						
Gain limited sensitivity (-1dB video signal) Carrier level of test signal	A2	BU4			33	dB μ V

PARAMETER	TEST SIGNAL	TEST POINT	MIN.	TYP.	MAX.	UNIT
Audio output characteristics Specification valid for : B/G, D/K and I modes						
AF output level (C7 = 0) measured via LP 20 kHz filter, RMS detector 50 μ s de-emphasis for AF1 at 1 kHz (C5 = 1, C6 = 1)	A2 + B3	BU6	400	500	600	mVrms
Specification valid for : L/L' mode (C5 = 0) modulation = 54%	A1 + B2 or A3 + B6	BU6	350	450	550	mVrms
AF output level (C7 = 0)						
Specification valid for : B/G, D/K, I modes						
THD (Total Harmonic Distortion) Signal-to -Noise ratio measured via LP 20 kHz filter, RMS detector 50 μ s de-emphasis for AF1 at 1 kHz (C5 = 1, C6 = 1)	A2 + B3	BU6	- 50	0.2 63	0.6 -	% dB
Specification valid for : L/L' mode						
THD (Total Harmonic Distortion) Signal-to -Noise ratio measured via LP 20 kHz filter, RMS detector for AF1 at 1 kHz	A1 + B2 or A3 + B6	BU6	- 42	0.8 50	1.5 -	% dB
Specification valid for : B/G, D/K and I modes (S/N = 40 dB) (C5 = 1, C6 = 1)	A2 + B3	BU6			40	dB μ V
Audio sensitivity						
Specification valid for : L/L' mode (S/N = 38 dB)	A1 + B2 or A3 + B6	BU6			45	dB μ V
Audio sensitivity						

Multi-Standard Miniature Video Module**FQ1216AME MK4****APPLICATION INFORMATION****DEMONSTRATION KIT**

A demonstration kit is available for the FQ1216AME (software, Application Note and evaluation board). Please contact your local Sales Engineer for details about the price and availability

I²C PROGRAMMING

For information regarding general aspects of I²C bus control see 'The I²C-bus and how to use it', published by Philips Semiconductors under the code : 9398 393 40011.

The FQ1216AME contains two I²C transceivers, one in the tuner part and one in the IF part. It is imperative to ensure that both I²C devices are programmed correctly according to their addresses

If in doubt, please refer to the demonstration software.

Tuner Part Programming (Write Mode)**BIT ALLOCATION**

(WRITE MODE , R/W = 0).

Write Data	MSB	bit6	bit5	bit4	bit3	bit2	bit1	LSB	ACK
Address Byte ADB	1	1	0	0	0	MA1	MA0	R/W=0	A
Divider Byte 1 DB1	0	N14	N13	N12	N11	N10	N9	N8	A
Divider Byte 2 DB2	N7	N6	N5	N4	N3	N2	N1	N0	A
Control Byte CB	1	CP	T2	T1	T0	RSA	RSB	OS	A
Bandswitch Byte BB	P7	P6	P5	P4	P3	P2	P1	P0	A
Auxiliary Byte AB (note *)	ATC	AL2	AL1	AL0	0	0	0	0	A

Note *: By default it is set to AL2=0, AL1=1, AL0=0. This sets the tuner TOP to 112 dBuV upon power-on reset.

ADDRESS SELECTION (BYTE ADB)

Voltage at terminal 6	Address	MA1	MA0
0 0.1 V _{cc}	C0	0	0
0.2.....0.3 V _{cc}	C2	0	1
0.4 0.6 V _{cc}	C4	1	0
0.9 V _{cc} 5 V	C6	1	1

Note: If the AS pin is left floating, the internal biasing will automatically set the address to C2.

Multi-Standard Miniature Video Module**FQ1216AME MK4**PROGRAMMABLE DIVIDER SETTING (BYTES DB1 AND DB2)

Divider ratio:
$$N = F_{OSC}/F_{SS}$$

where $F_{OSC} = (F_{RF} + F_{IF})$ and F_{SS} is the step-size set by RSA and RSB as described below.

$$N = 8192*N_{13} + 4096*N_{12} + 2048*N_{11} + 1024*N_{10} + 512*N_9 + 256*N_8 + 128*N_7 + 64*N_6 + 32*N_5 + 16*N_4 + 8*N_3 + 4*N_2 + 2*N_1 + N_0$$

Note: $F_{IF} = 38.9 \text{ MHz}$, except for L' mode. In this case $F_{IF} = 33.95 \text{ MHz}$

CONTROL BYTE CBCharge Pump Setting:

CP can be set to either 0 (low current) or 1 (high current).

CP = 1, charge pump current = 280uA results in fastest tuning (default mode)

CP = 0, charge pump current = 60uA results in moderate speed tuning with slightly better residual oscillator

Test Mode Setting:

T2 = 0, T1 = 0, T0 = 1 for normal operation (default)

T2 = 0, T1 = 1, T0 = 1 indicates that Byte AB will follow Byte CB instead of Byte BB for the current IIC Byte sequence.

PLL Disabling:

OS=0 for normal operation,

OS=1 switches off the PLL tuning amplifier (PLL tuning is disabled)

Ratio Select Bits

RSA = 0, RSB = 0 gives 50 kHz step-size

RSA = 0, RSB = 1 gives 31.25 kHz step-size (for slow picture-search)

RSA = 1, RSB = 0 gives 166.7 kHz step-size

RSA = 1, RSB = 1 gives 62.5 kHz step-size (for normal picture-search)

BANDSWITCHING BYTE BB

PORTS	P0	P1	P2	P3	P4	P5	P6	P7
LOW BAND	1	0	0	0	0	X	X	X
MID BAND	0	1	0	0	0	X	X	X
HIGH BAND	0	0	1	0	0	X	X	X

Multi-Standard Miniature Video Module**FQ1216AME MK4**AUXILIARY BYTE AB

The AGC Take Over Point can be set by programming the following bits AL2, AL1, AL0

IF output level, symmetrical mode	Remark	AL2	AL1	AL0
115 dB μ V		0	0	0
115 dB μ V		0	0	1
112 dB μ V	default mode at POR	0	1	0
109 dB μ V	Recommended for negative modulation	0	1	1
106 dB μ V	Recommended for positive modulation	1	0	0
103 dB μ V		1	0	1
I _{AGC} = 0	External AGC . See remarks (1).	1	1	0
3.5 V	Disabled . See remarks (2).	1	1	1

Remarks:

- 1). The AGC detector is disabled. Both the sinking and sourcing current from the IC is disabled. The AGC output goes into a high impedance state and an external AGC source can be connected in parallel and will not be influenced.
- 2). The AGC detector is disabled and I_{AGC} = 9 μ A.

**It is recommended to set the internal AGC to 115 dB μ V (AL2=0, AL1=0, AL0=0) .
The IF AGC should be set according to the table on Pg 17 (see bits C0 to C4).**

Multi-Standard Miniature Video Module**FQ1216AME MK4****Important:**

ATC = AGC time constant.

We recommend to set the ATC = 0 for normal operation.

Tuner Part Programming (Read Mode)

BIT ALLOCATION (READ MODE R/W = 1)

	MSB	bit6	bit5	bit4	bit3	bit2	bit1	LSB	ACK
Address Byte ADB	1	1	0	0	0	MA1	MA0	R/W=1	A
Status Byte SB	POR	FL	1	1	AGC	A2	A1	A0	A

The following data can be read from the device through the status byte:

POR (power on reset): POR is internally set to 1 in case V_{cc} drops below 3V. The POR bit is reset when an end of data is detected by the PLL-IC.

FL: in lock flag (FL = 1 when the phase lock loop is in lock).

The loop must be phase-locked during at least 8 periods of the internal 7.8125 kHz reference-frequency (i.e. 1 msec) before the FL flag is internally set to 1.

AGC : internal AGC flag. AGC=1 when internal AGC is active (level below 3V)

A2, A1, A0 : Not used.

Multi-Standard Miniature Video Module**FQ1216AME MK4****IF Part Programming (Write Mode)**

The IF uses the new TDA9887 demodulation IC from Philips Semiconductors.

I²C Bus Control –format to WRITE (slave receives data)

S	SLAVE ADDRESS	R/W=0	A	SAD	A	DATA	A	P
---	---------------	-------	---	-----	---	------	---	---

BIT	FUNCTION
S	START condition
Standard SLAVE ADDRESS	100 0011X where X is the value of R/W See Pg 20
R/W = 0	Write Mode
A	acknowledge, generated by slave
SUBADDRESS (SAD)	See table below
DATA	Bytes B, C and E (described below)
P	STOP condition

SUB ADDRESS BYTE (SAD, first byte after slave address)

DATA BYTE FOLLOWING SAD	MSB							LSB	
	D7	D6	D5	D4	D3	D2	D1	D0	
SWITCHING (B DATA)	0	0	X	X	X	X	0	0	
ADJUST (C DATA)	0	0	0	0	0	0	0	1	
DATA (E DATA)	0	0	0	0	0	0	1	0	

DESCRIPTION OF THE BITS OF THE VARIOUS DATA BYTES

DATA BYTE	BIT	SUBADDRESS	FUNCTION
B DATA	B0	SWITCHING	video mode (sound trap)
	B1	SWITCHING	auto mute FM
	B2	SWITCHING	carrier mode
	B3 and B4	SWITCHING	TV standard positive/negative modulation (B3=0)
	B5	SWITCHING	forced mute audio
	B6	SWITCHING	not used
	B7	SWITCHING	L/L' Sound
C DATA	Co to C4	ADJUST	TOP adjustment
	C5 to C6	ADJUST	de-emphasis
	C7	ADJUST	audio gain
E DATA	E0 and E1	DATA	standard sound carrier
	E2 to E4	DATA	standard video IF
	E5	DATA	VIF, SIF and tuner minimum gain
	E6	DATA	L standard PLL gating HIGH
	E7	DATA	VIF-AGC

Multi-Standard Miniature Video Module

FQ1216AME MK4

For convenience, the programming has been consolidated as a single table.

Video Trap Bypass	B 0	0	0	0	0	0	X
Auto Mute FM	B 1	1	1	1	1	1	X
Carrier Mode	B 2	1	1	1	1	1	X
FM Mode	B 3	0	0	0	0	0	X
TV Modulation	B 4	1	1	1	0	0	X
Forced Mute Audio	B 5	0	0	0	0	0	1
Not Used (OP1)	B 6	0	0	0	0	0	X
L/L' Sound (OP2)	B 7	1	1	1	1	0	X
TOP Adjustment See remarks *	C 0	0	0	0	0	0	X
	C 1	0	0	0	0	1	X
	C 2	0	0	0	0	1	X
	C 3	0	0	0	0	1	X
	C 4	1	1	1	0	0	X
De-Emphasis	C 5	1	1	1	0	0	X
De-Emphasis Time	C 6	1	1	1	1	1	X
Audio Gain	C 7	0	0	0	0	0	X
Sound Intercarrier	E 0	1	0	1	1	1	X
	E 1	0	1	1	1	1	X
Video IF	E 2	0	0	0	0	0	X
	E 3	1	1	1	1	0	X
	E 4	0	0	0	0	1	X
IF Gain	E 5	0	0	0	0	0	X
L/L' PLL Gating	E 6	1	1	1	1	1	X
VIF AGC Output	E 7	0	0	0	0	0	0
Description	Bits	B/G	I	D/K	L	L'	Force Audio Mute
		TV Systems					

* For optimum setting between overall picture quality and signal handling to fulfill CISPR20/EN55020 requirements, we recommend to use these settings below .

However we recommend customers have the choice to make their own setting based on their own application. For example, for cable TV networks, the TOP has to be -4 dB or lower to prevent intermodulation problems.

Top Setting	B/G/DK/I	L/L'
Low Band	+ 0 dB	- 2 dB
Mid Band	-2 dB	- 2 dB
High Band	+ 0 dB	- 2 dB

Multi-Standard Miniature Video Module**FQ1216AME MK4****IF Part Programming (Read Mode)**

The IF uses the new TDA9886 demodulation IC from Philips Semiconductors.

I²C Bus Control –format to READ (slave transmits data)

S	SLAVE ADDRESS	R/W=1	A	DATA	AN	P
---	---------------	-------	---	------	----	---

BIT	FUNCTION
S	START condition
Standard SLAVE ADDRESS	100 0011X where X is the value of R/W
R/W = 1	Read Mode
A	acknowledge, generated by slave
DATA	Byte D (described below)
AN	acknowledge not, generated by the master
P	STOP condition, generated by the master

The master generates an acknowledge when it has received the dataword READ. The master next generates an acknowledge, then slave begins transmitting the dataword READ, and so on until the master generates no acknowledge and transmits a STOP condition.

Byte D (Transmitted byte after read condition - Status Register)

FUNCTION	MSB							LSB
	D7	D6	D5	D4	D3	D2	D1	D0
READ	AFCWIN	VIFL	FMIFL	AFC4	AFC3	AFC2	AFC1	PONR

PONR = 1 After power-on reset or after supply breakdown

PONR = 0 After a successful reading of the status register

FMIFL = Not used.

VIFL = 1 Video IF level HIGH

VIFL = 0 Video IF level LOW

Multi-Standard Miniature Video Module**FQ1216AME MK4**

AFC STATUS

It is possible to monitor the AFC status via the D1-D4 bits.

Function	Bits			
	D4	D3	D2	D1
AFC F_{VIF} vs F_0 (1)				
$F_{VIF} \leq F_0 - 187.5$ kHz	0	1	1	1
$F_{VIF} = F_0 - 162.5$ kHz	0	1	1	0
$F_{VIF} = F_0 - 137.5$ kHz	0	1	0	1
$F_{VIF} = F_0 - 112.5$ kHz	0	1	0	0
$F_{VIF} = F_0 - 87.5$ kHz	0	0	1	1
$F_{VIF} = F_0 - 62.5$ kHz	0	0	1	0
$F_{VIF} = F_0 - 37.5$ kHz	0	0	0	1
$F_{VIF} = F_0 - 12.5$ kHz	0	0	0	0
$F_{VIF} = F_0 + 12.5$ kHz	1	1	1	1
$F_{VIF} = F_0 + 37.5$ kHz	1	1	1	0
$F_{VIF} = F_0 + 62.5$ kHz	1	1	0	1
$F_{VIF} = F_0 + 87.5$ kHz	1	1	0	0
$F_{VIF} = F_0 + 112.5$ kHz	1	0	1	1
$F_{VIF} = F_0 + 137.5$ kHz	1	0	1	0
$F_{VIF} = F_0 + 162.5$ kHz	1	0	0	1
$F_{VIF} \geq F_0 + 187.5$ kHz	1	0	0	0

Note

1. F_0 = nominal F_{VIF}

AFCWIN = 1 F_{VIF} inside AFC Window

AFCWIN = 0 F_{VIF} outside AFC Window

PROGRAMMING EXAMPLES

Example 1: To tune to Ch E21 (471.25 MHz) in high band

$F_{osc} = 471.25 + 38.9 = 510.15$ MHz

$N = (510.15 \text{ MHz}) / (62.5 \text{ kHz}) = 1F E2$ (Hexadecimal)

So DB1 = 1F H

and DB2 = E2 H

CB = 86H if CP is set to low or CB = C6H if CP is set to high

BB = 44H (because of high band selected)

AB = 00 H

Multi-Standard Miniature Video Module

FQ1216AME MK4

Example 2 : To tune to a PAL B/G program at 471.25 MHz

	MSB	Bit6	Bit5	Bit4	Bit3	Bit2	Bit1	LSB	
Address									
ADB	1	1	0	0	0	MA1	MA0	R/W	= C2
Write									
DB1	0	N14	N13	N12	N11	N10	N9	N8	= 1F
DB2	N7	N6	N5	N4	N3	N2	N1	N0	= E2
CB	1	CP	T2	T1	T0	RSA	RSB	OS	= 86
BB	SW	FMST	P5	P4	P3	High	Mid	Low	= 44
AB	ATC	AL2	AL1	AL0	0	0	0	0	= 40
Read									
SB	POR	FL	1	1	AGC	A2	A1	A0	= 00
Close									

Tuner I²C program

	MSB	Bit6	Bit5	Bit4	Bit3	Bit2	Bit1	LSB	
Address									
Slave	1	0	0	M1	0	1	M2	R/W	= 86
Sub (SAD)	0	0	0	0	0	0	SAD1	SAD0	= 00
Write									
Switching (B)	L	FMS	FMA	TVM	FM	CM	AMF	VM	= 56
Adjust (C)	AG	DE1	DE0	TOP4	TOP3	TOP2	TOP1	TOP0	= 70
Data (E)	AGC	Gate	GIF	VIF2	VIF1	VIF0	SIF1	SIF0	= 49
Read									
Status (SR)	AFCW	VIFL	FMIFL	AFC4	AFC3	AFC2	AFC1	POR	= 00
Close									

IF I²C program

Example 3 : To tune to a SECAM program at 471.25 MHz (L system)

	MSB	Bit6	Bit5	Bit4	Bit3	Bit2	Bit1	LSB	
Address									
ADB	1	1	0	0	0	MA1	MA0	R/W	= C2
Write									
DB1	0	N14	N13	N12	N11	N10	N9	N8	= 1F
DB2	N7	N6	N5	N4	N3	N2	N1	N0	= E2
CB	1	CP	T2	T1	T0	RSA	RSB	OS	= 86
BB	SW	FMST	P5	P4	P3	High	Mid	Low	= 44
AB	ATC	AL2	AL1	AL0	0	0	0	0	= 40
Read									
SB	POR	FL	1	1	AGC	A2	A1	A0	= 00
Close									

Tuner I²C program

	MSB	Bit6	Bit5	Bit4	Bit3	Bit2	Bit1	LSB	
Address									
Slave	1	0	0	M1	0	1	M2	R/W	= 86
Sub (SAD)	0	0	0	0	0	0	SAD1	SAD0	= 00
Write									
Switching (B)	L	FMS	FMA	TVM	FM	CM	AMF	VM	= 46
Adjust (C)	AG	DE1	DE0	TOP4	TOP3	TOP2	TOP1	TOP0	= 4E
Data (E)	AGC	Gate	GIF	VIF2	VIF1	VIF0	SIF1	SIF0	= 4B
Read									
Status (SR)	AFCW	VIFL	FMIFL	AFC4	AFC3	AFC2	AFC1	POR	= 00
Close									

IF I²C program

Multi-Standard Miniature Video Module

FQ1216AME MK4

LOADING OF I²C BUS

The FQ1216AME/ H-4 contains series impedances in the SCL and SDA lines : a total of R= 220 ohms leading to the tuner part and R= 300 ohms leading to the IF demodulation part. See the diagram below. Both lines also have capacitive loads of C= 22 pF max. Care must be taken to ensure that the total load on the bus does not exceed that as mentioned in the brochure "The I²C-bus and how to use it".

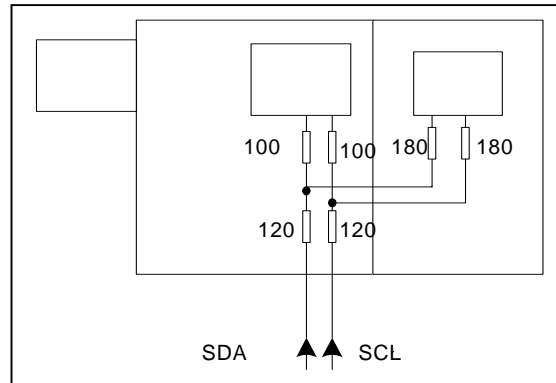

AUDIO EMPHASIS

The audio de-emphasis (50 us) is set by the bits C5 and C6

C5=0 de-emphasis OFF

C5=1 de-emphasis ON

C6=1 50us

C6=0 75 us

De-emphasis should be switched off in L/L' mode since it is not required for AM sound.

CVBS LOAD / TUNING VOLTAGE SUPPLY

A video buffer is built into the frontend to enable the unit to drive a 75 Ω load directly (e.g. into the SAA711x directly). A DC-DC converter for providing the required tuning voltage supply is already built into the FQ1216AME.

PIP APPLICATION

By connecting a 1K resistor to ground at pin 6 and a 2K2 resistor to ground at pin 11, the tuner and IF addresses of the second (PIP) FQ1216AME module can be set to # C0 and # 84 respectively. In this way, the address of the main frontend remains at # C2 and # 86.

CVBS Output level

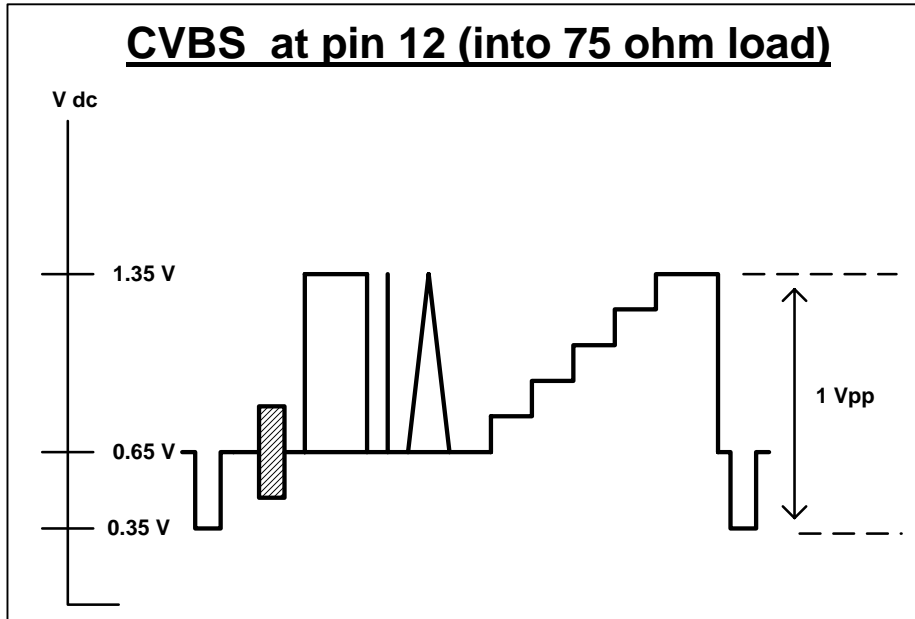

VIDEO SIGNAL TO NOISE RATIO

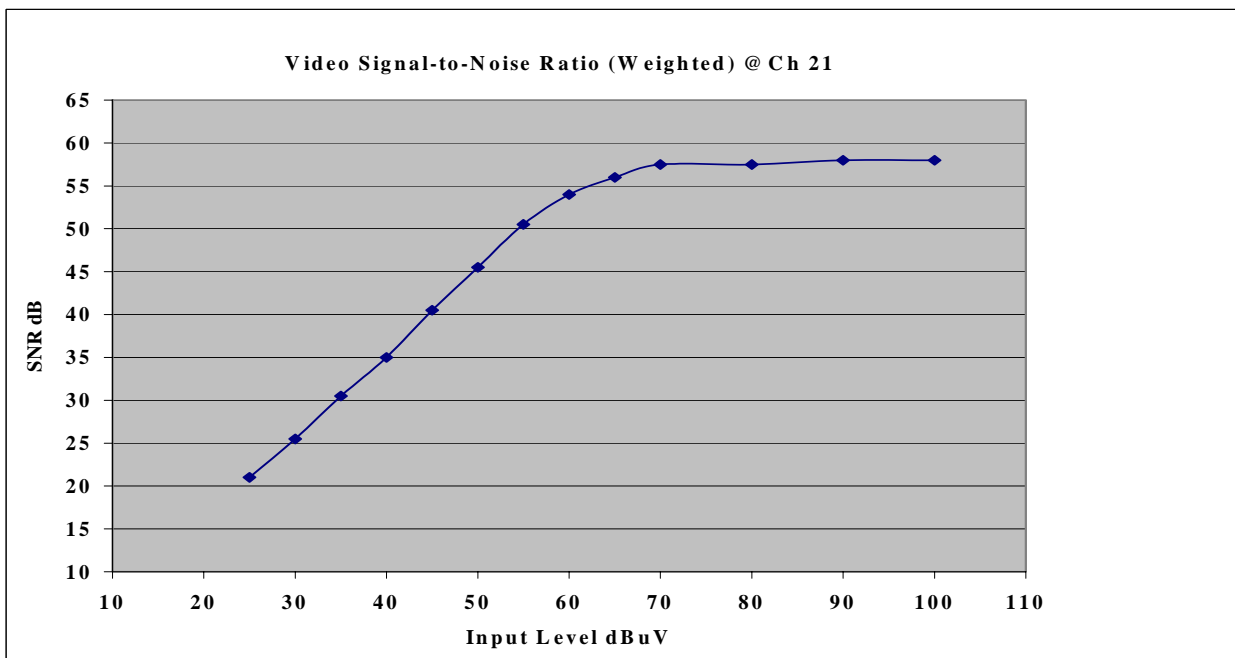

Multi-Standard Miniature Video Module**FQ1216AME MK4****MECHANICAL DATA**

See product drawing 3139 149 0182

AERIAL CONNECTIONS

Pin connector. See product drawing 3139 149 0182

SOLDERABILITY

The solderability of pins and mounting tags when tested initially and after 16 hour steam ageing in accordance with "IEC 60068-2-20", test Ta, method 1 (solder bath 235°C for 2s), results in a wetted area of 95%. No de-wetting will occur when soldered at 260°C for 5s.

RESISTANCE TO SOLDERING HEAT

The product will not be damaged when tested in accordance with "IEC 60068-2-20", test Tb, method 1A (solder bath 260°C for 10±1 s).

MASS

Approximately 24g.

ROBUSTNESS OF PINS

The pins will not be damaged when tested in accordance with "IEC 60068-2-21":

- Test Ua1, tensile of 10N in axial direction
- Test Ua2, thrust of 4N in axial direction

PUNCHING PATTERN OF CHASSIS PCB

For optimum mounting of the tuner to a PCB, the punching pattern is recommended (see 3139 149 0182).

The tuner must be mounted without clearance between the tuner supporting surface and the printed circuit board (PCB). When mounted in this way, the tuner must be soldered to the PCB. This can be achieved by pressing the unit vertically onto the PCB during soldering.

PACKAGING INFO

The products are packed in the carton box and transferred to customers by Pallet Transport.

Mounting Type	Dimension B x w x h (cm)	No. of sets	Gross Wt (Kg)
Carton	46x3.4x5.6	90	2.76
Pallet	120x105x105	9000	298

Carton Boxes are made of Corrugated Fibreboard which are free of environmentally banned substances.

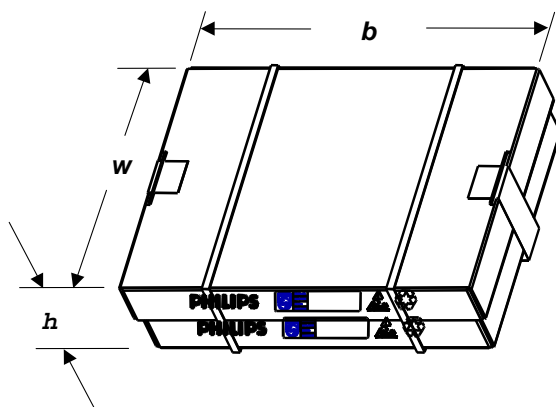
Example of Carton Box:

Multi-Standard Miniature Video Module

FQ1216AME MK4

See product drawing 3139 149 0182 – Page 1 (dated on 04-09-01)

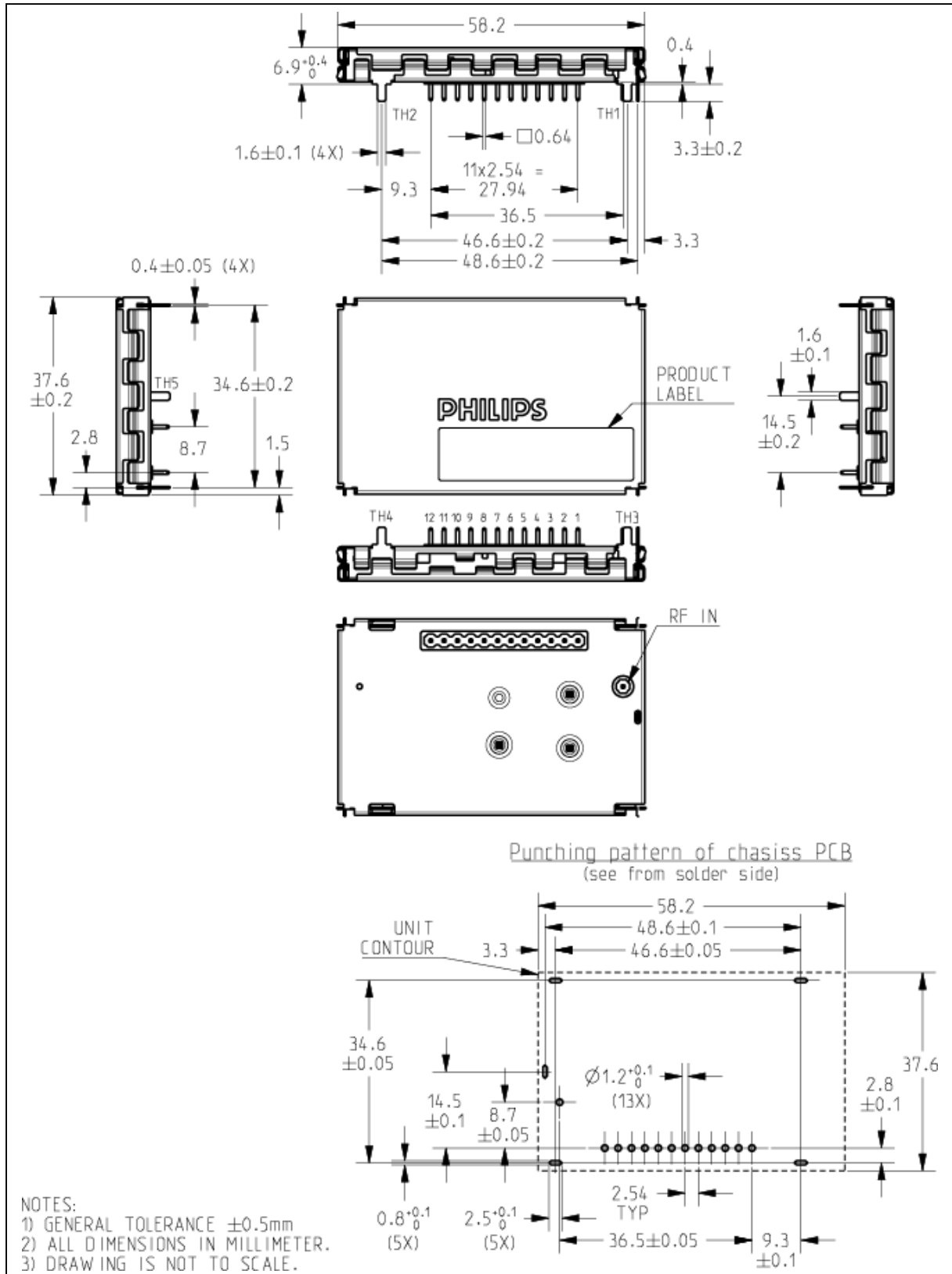

Multi-Standard Miniature Video Module**FQ1216AME MK4****DEFINITIONS**

Data sheet status	
Objective specification	This data sheet contains target or goal specifications for product development.
Preliminary specification	This data sheet contains preliminary data; supplementary data may be published later.
Product specification	This data sheet contains final product specification.
Application Information	
Where application information is given, it is advisory and does not form part of the specification	

LIFE SUPPORT APPLICATIONS

These products are not designed for use in life support appliances, devices, or systems where malfunction of these products can reasonably be expected to result in personal injury. Philips customers using or selling these products for use in such applications do so at their own risk and agree to fully indemnify Philips for any damages resulting from such improper use or sale.

PURCHASE OF PHILIPS I²C COMPONENTS

Purchase of Philips I²C components conveys a license under the Philips I²C patent to use the components in the I²C systems to the I²C specification defined by Philips. This specification can be ordered using the code 9398 393 40011.

RF Solutions Sales Offices

Internet: www.rfsolutions.philips.com

© Philips Electronics N.V. 2005.

All rights are reserved. Reproduction in whole or in part is prohibited without the prior written consent of the copyright owner. The information presented in this document does not form part of any quotation or contract, is believed to be accurate and reliable and may be changed without notice. No liability will be accepted by the publisher for any consequence of its use. Publication thereof does not convey nor imply any license under patent- or other industrial or intellectual property rights.

